

HOLE TO ACCEPT 5/16" FLATHEAD SLOTTED MACHINE SCREW (4 PLACES)

HUBS 4" & 6"

HUB	"A"	"B"	"C"	"D"	"E"	"F"
4"	6 1/2"	3 3/8"	5 7/8"	5 1/8"	2 1/4"	4 1/8"
6"	8 1/4"	4 5/8"	7 3/4"	7 1/8"	2 1/4"	6 1/8"
8"	12 1/4"	5 5/8"	10"	9 1/4"	2 1/4"	8 1/8"

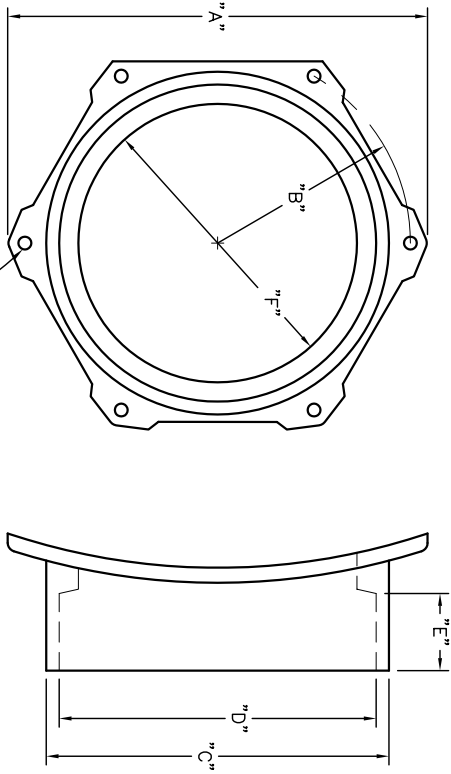

HOLE TO ACCEPT 3/8" FLATHEAD SLOTTED MACHINE SCREW (6 PLACES)

HUBS 8"

COMMONLY USED SEALANTS BETWEEN HUB AND PIPE

- ORIGINALLY DESIGNED FOR USE WITH OAKUM AND LEAD.
- PLASTIC SEAL™ BY HERCULES® CAN BE USED TO REPLACE LEAD. (CAN BE USED WITH OR WITHOUT OAKUM).
- "PIPE SEAL" BY CATEY®, CAN BE USED TO REPLACE LEAD.
- CAN BE GROUTED WITH MASTERFLOW® 928 BY BASF.

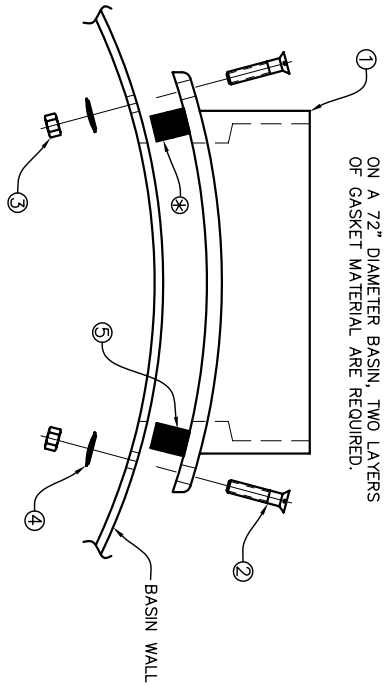

* NOTE: WHEN INSTALLING THE 8" HUB ON A 72" DIAMETER BASIN, TWO LAYERS OF GASKET MATERIAL ARE REQUIRED.

INSTALLATION INSTRUCTIONS:

1. FIND LOCATION WHERE CENTER OF HUB WILL BE POSITIONED ON BASIN.
2. DRILL OR CUT HOLE IN BASIN TO "F" DIMENSION.
3. PLACE HUB ON BASIN WALL AND DRILL MOUNTING HOLES IN BASIN WALL TO MATCH HUB.
4. APPLY GASKET TO BACK OF HUB, MOUNT HUB ON BASIN.
5. INSERT BOLTS, WASHERS AND NUTS, THEN TIGHTEN IN PLACE.

ITEM NO.	PART NO.	ITEM DESCRIPTION	4" HUB	6" HUB	8" HUB
5	70954	SEAL, 1/2" TK x 3/4" WIDE x ft	1.5	2	6
4	70632	WASHER, 3/8" SEALING BARTITE	-	-	6
3	70915	NUT, 3/8" NYLOCK SS	-	-	6
2	70955	BOLT, 3/8" x 1 1/2" FH SL SS	-	-	6
4	70145	WASHER, 5/16" SEALING BARTITE	4	4	-
3	70914	NUT, 5/16" NYLOCK SS	4	4	-
2	70449	BOLT, 5/16" x 1 1/2" FH SL SS	4	4	-
1	70012	HUB, C.I. 8" CASTING	-	-	1
1	70014	HUB, C.I. 6" CASTING	-	1	-
1	70013	HUB, C.I. 4" CASTING	1	-	-

-----PARTS LIST-----



STEELE PLASTICS, INC.

P.O. Box 1076 / 1280 Sturgis Rd.
Conroy, AR 72033 (501) 327-5122
Fax (501) 327-0807

TITLE CAST IRON INLET HUB

PROJECT

REV. B

JOB NO.

CUSTOMER

P.O. NO.

HUB-0001

DWG. NO.