

INSPECTION PLATE MODIFICATION

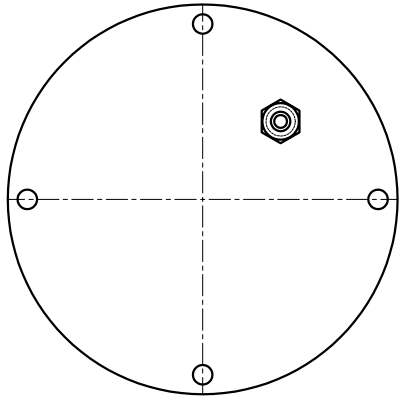

LCM-1  
(1 CORD GRIP)

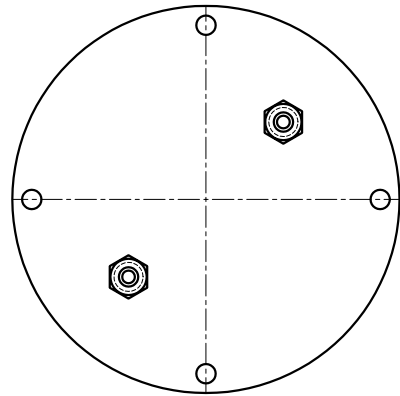

LCM-2  
(2 CORD GRIPS)

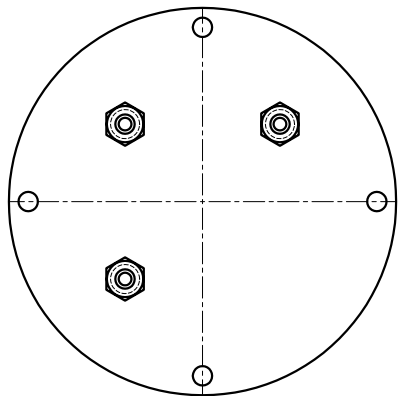

LCM-3  
(3 CORD GRIPS)

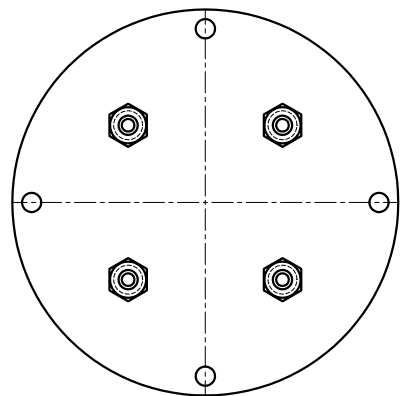

LCM-4  
(4 CORD GRIPS)



STEELE PLASTICS, INC.  
P.O. Box 1076 / 1280 Sturgis Rd.  
Conway, AR 72033  
(501) 327-5122 Fax (501) 327-0807

TITLE LEVEL CONTROL MODIFICATION OPTIONS

PROJECT

JOB NO.

P.O. NO.

CUSTOMER

DWG. NO.

LCM